

PERSONA



ABRAZO Lounge Chair



Espresso Leather



Mode Spindle by Maharam

ABRAZO Lounge Chair

The Abrazo Lounge Chair unfolds as a study in softness and gesture, defined by movement where tension and release create rhythm and structure. Like an embrace, the folds are both ornamental and structural, shaping the lounge chair while inviting touch. Available in COM (Customer's Own Material) and COL (Customer's Own Leather).

PRODUCT SPECIFICATIONS

MATERIALS Wood and Metal Structure | Foam | Fabric or Leather

DIMENSIONS 34 W | 38 D | 28 H in
86 W | 96 D | 71 H cm

WEIGHT 90 lbs | 40 kg

FABRIC REQUIREMENTS COM 9 yards | COL 165 sqft
Swatch required for approval

SHIPPING Worldwide shipping
Quotes upon request

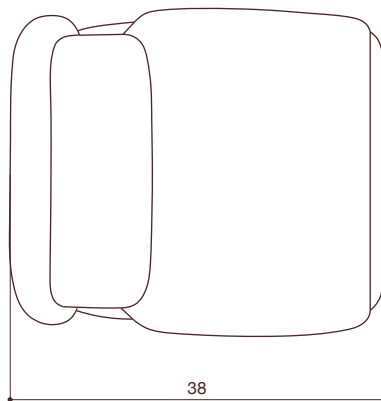
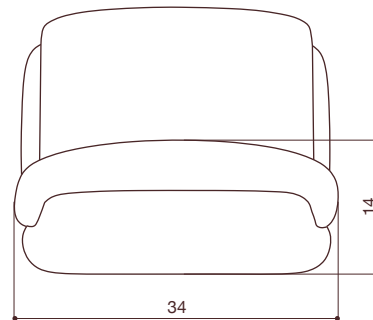
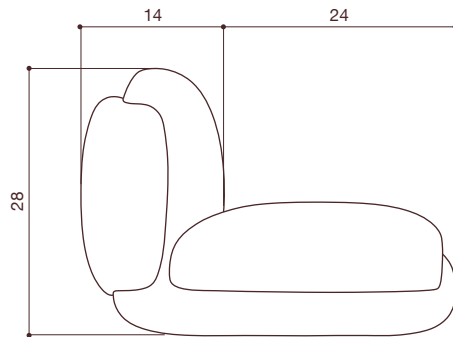

Handmade in Los Angeles

Every effort is made to ensure an accurate representation of product colors, finishes, and dimensions; however, due to the handmade nature of this product, slight variations may occur. Color swatches are provided for reference only. Estudio Persona cannot guarantee an exact color match for any product finishes. All designs are protected under copyright law. Estudio Persona holds the exclusive manufacturing and distribution rights worldwide. Unauthorized copying will be prosecuted.

MATERIALS AND FINISHES

Fabric Name Mode - Maharam
Composition 80% PC Recycled Polyester, 20% polyester, 100,000 double rubs Wyzenbeek, Bleach Cleanable

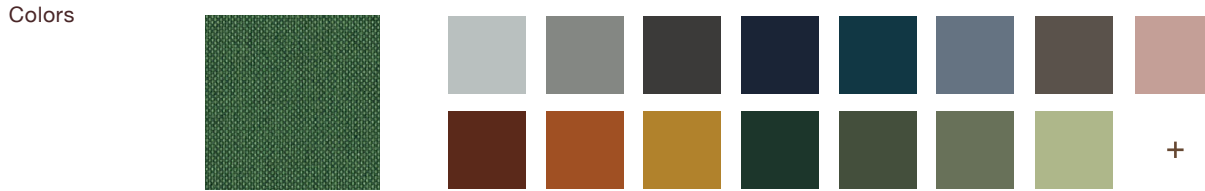

Fabric Name Mohair Supreme - Maharam
Composition 100% Mohair, 70,000 double rubs Wyzenbeek



Name Leather
Composition Vegetable tanned natural cowhide. 1.0-1.2mm thickness

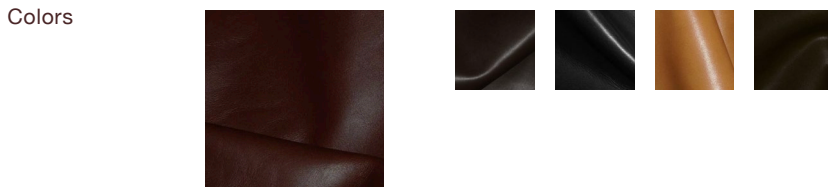

CLEANING INSTRUCTIONS

Fabric
It is recommended to vacuum the fabric regularly and to use non-abrasive textile cleaners for the gentle removal of any stains.

Leather
To prevent fingerprint marks, always handle items while wearing gloves. If the leather item presents stains or dirt, first remove any loose debris using a dry, soft-bristled brush. Then, use a lightly dampened cloth with distilled or bottled water to clean the surface. Ensure that cleaning is performed with smooth, continuous motions across the entire surface, avoiding excessive focus on any single area to maintain a uniform appearance.

Please note:
Natural materials will come with peculiarities and develop a characteristic patina over time.